

# Simply Septics



**Guide for Delaware Homeowners  
about On-Site Wastewater  
Treatment and Disposal Systems**



# On-Site Wastewater Treatment and Disposal Systems

## A Quick Guide through the Three-Step Process:

### How to Obtain a Site Evaluation, Septic Permit, and a Licensed System Contractor

Obtaining an on-site wastewater treatment and disposal system (OWTDS) – more commonly known as a septic system – is a three-step process in Delaware. Under Chapter 60, Title 7 of the Delaware Code, a site evaluation must be performed on unimproved lots prior to sale.

## Step 1 – Site Evaluation

- ◆ Have a site evaluation performed by a licensed Class D soil scientist to determine what type of disposal system can be installed on the parcel under current regulations.
- ◆ The soil scientist performs fieldwork, prepares site evaluation report, and submits it to DNREC's Groundwater Discharge Section (GWDS), with appropriate fee, for approval.
- ◆ GWDS reviews work and approves/denies the site evaluation within 10 working days of receipt.
- ◆ Site evaluation is mailed to the owner or authorized agent, or can be picked up on request.

## Step 2 – System Design and Permitting

- ◆ Hire a licensed system designer to design the OWTDS and obtain a permit.
- ◆ Select a Class B designer for gravity systems.
- ◆ Select a Class C designer for engineered, innovative/alternative, and pressure-dosed systems.
- ◆ All designs are submitted to GWDS, with appropriate fee, and become permits upon approval.
- ◆ **Engineered and Gravity system permits** take approximately 20 working days from receipt to final approval.

## Step 3 – Choose an Installer

Choose a licensed Class E system contractor to install your OWTDS.

*Listings of all licensees and copies of the Regulations Governing the Design, Installation and Operation of On-Site Wastewater Treatment and Disposal Systems are available online or from DNREC's Dover and Georgetown offices. For more information, call 302-739-9947 or 302-856-4561.*

## Extending the Lifespan of Your On-Site Wastewater Treatment and Disposal System

- Do:**
- ◆ Have your septic tank pumped by a Class F liquid waste hauler every two to three years. Depending upon your family size, amount of wastewater generated, age of the system, or if you have a garbage disposal, you may need to pump more frequently. The effluent filter requires periodic cleaning to prevent clogging. **Ensure the wastehauler pumps both compartments of your tank through the manhole covers and that all the sludge is removed.**
  - ◆ Reduce the amount of water you use by taking shorter showers and/or installing a water-saver showerhead, which can reduce water consumption from five to six gallons per minute to as little as two gallons per minute.
  - ◆ To reduce water usage by about 50 percent, use faucet aerators in the kitchen and bathroom sinks.
  - ◆ When using your dishwasher and washing machine, do full loads and average one load per day to help your drainfield accept the wastewater generated.
  - ◆ Install low-flush toilets in your bathrooms or, if you have an older toilet, use a plastic jug that displaces some of the water needed to fill the tank. Reducing the number of flushes can also be a water-saving technique.
  - ◆ Use biodegradable toilet paper. Look for products labeled "approved for septic tank use."
  - ◆ Contact a licensed Class E system contractor when you have a problem with your disposal system.

**Saving  
water  
saves you  
money!**





## Don't:

- ◆ Construct buildings or allow vehicular traffic over your drainfield and replacement area. Either may result in costly damage.
- ◆ Plant any deep-rooted trees or shrubs within 10 feet of your disposal system. The roots can grow into the drainfield and reduce its capacity to handle wastewater.
- ◆ Pour grease, paints, caustic or oily liquids, fuels, cooking fats or motor oils into sinks or toilets. These can kill the bacteria and/or plug your disposal system.
- ◆ Repair your disposal system without obtaining the proper permit from GWDS. Only use Class E licensed system contractors when doing repair work. Class F and Class H wastehaulers are authorized to make minor repairs.
- ◆ Climb into a septic tank. Methane and hydrogen sulfide gases, which are present from the decomposition processes, may cause illness or death.
- ◆ Dispose of coffee grounds, sanitary napkins, tampons, condoms, cigarette butts, or disposable diapers in the toilet or sink.

## How Your On-Site Wastewater Treatment and Disposal System Functions

OWTDS are individual water treatment facilities on your property that collect, treat, and dispose of wastewater, unlike municipal wastewater treatment facilities, which receive wastewater from multiple locations. OWTDS components can include a septic tank, distribution box, dosing chamber, and drainfield. If properly maintained, a disposal system can last 15 to 20 years.

The septic tank collects and partially treats household wastewater. Approximately 60 percent of the solids are broken down by bacteria into liquid and gas. During the two-to-three day treatment period, lighter-than-water solids such as grease, oils, and toilet paper float to the top and form a scum layer. The solids, which are heavier than water, sink to the bottom, forming sludge. The cloudy water in between is known as effluent.

Processes in a septic tank take place anaerobically, which means without the presence of oxygen. Gas produced is discharged through the plumbing vent system. Methane and hydrogen sulfide are dangerous gases produced through these natural processes, so use extreme care when inspecting or looking into your tank.

The final treatment step for effluent, as it returns to groundwater, is a drainfield, consisting of a series of perforated pipes placed in either an aggregate-filled trench or bed, or placed in aggregate-free chambers to distribute effluent evenly. The wastewater slowly trickles through these materials and into the soil beneath. Soil bacteria break down the effluent aerobically, which means with the presence of oxygen.

Synthetic materials are now available for use in chambers as alternatives to conventional materials such as stone. Synthetic materials weigh less than stone, allowing quick installation and easier handling, and are cleaner and free of fine particles.

As effluent seeps into the soil toward natural groundwater, toxins, viruses, and other pollutants are removed. Clay particles in the soil chemically attract and hold sewage nutrients (phosphates and ammonium), heavy metals, and disease-carrying organisms. However, chemical additives, paint, grease, fats, or thinners will kill the bacteria, clog the drainfield to eventually make it ineffective, and contaminate the groundwater.

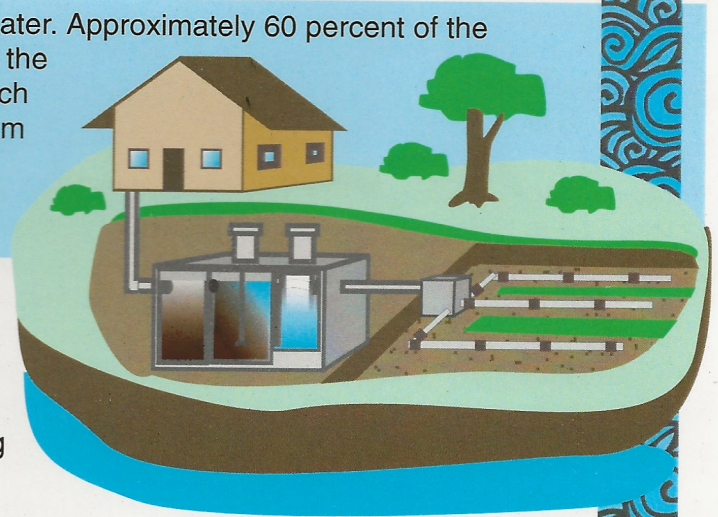



## Repairing or Replacing a Malfunctioning On-Site Wastewater Treatment and Disposal System

A malfunctioning or failed OWTDS is not only a nuisance, but also a public health hazard. Repairing or replacing a problem system will protect your family, friends, and drinking water. So how do you know your OWTDS is malfunctioning? Here are some warning signs.

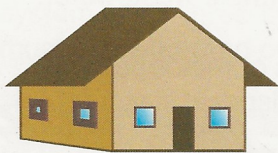

### House

- ◆ Slowly draining sinks and toilets
- ◆ Plumbing backups
- ◆ Gurgling in the plumbing



### Yard

- ◆ Damp soil or ponding over system
- ◆ Grass grows faster and greener
- ◆ Sewage odor near the system

If you discover one or more of these warning signs, contact a licensed Class E system contractor or Class H system inspector to have your system inspected. The system inspector must report findings to the GWDS within 72 hours of the inspection. Together, GWDS and the Class E system contractor will advise you on what they find and what action to take. If your disposal system has failed, you must replace it with a system that conforms to current regulations.

Depending on the type of system, minor adjustments may correct your problem, such as cleaning the effluent filter. Systems permitted after March 2002 are required to have risers extending above grade and an effluent filter. It is the property owner's responsibility to provide necessary filter maintenance. Repairs can help cure problems such as excessive water usage, improper drainfield size, or replacing older septic tanks.

## State Funds Available to Repair/Replace Failed Wastewater Treatment and Disposal Systems

DNREC has dedicated a portion of the State Revolving Fund (SRF) to help Delawareans pay for the cost of repairing or replacing OWTDS. Low interest loans are available to low-to-moderate income homeowners. As these loans are repaid, money is returned to the revolving fund to make more loans. For more information about the SRF loan program, please contact DNREC's Environmental Finance Section at 302-739-9941. A non-refundable application fee is required. All information you supply with your application will be used solely for evaluating your application.

## Record-Keeping Tips for Repairs and Maintenance Purposes

Knowing the location of your OWTDS is very important for maintenance, repairs, pumping, and traffic avoidance. All information pertaining to your disposal system should be kept together, such as inside this brochure. Here are some tips for good septic record keeping:

- ◆ File detailed records of all maintenance performed, inspections, and any problems.
- ◆ Obtain a copy of the permit from the contractor and/or DNREC for your files.
- ◆ If unable to get a copy of the permit, make a map or drawing of the location of your OWTDS.
- ◆ Keep a record of pumping dates and receipts; a septic tank pumping log is included with this guide.

Visit us on the web at [www.dnrec.delaware.gov](http://www.dnrec.delaware.gov).



This brochure was originally designed and compiled by DNREC Environmental Scientist Jack Hayes. This revised edition was edited by Senior Environmental Compliance Specialist Tish Boyd, Environmental Control Technician Brandon Ranalli, Environmental Scientist Jenwei Tsai, and Environmental Program Manager Ping Wang, with assistance from Burns & Ellis Realtors, Clean Delaware, Inc., Eastern Shore Soil Services, Hollis Warren Waste Water Mgmt., Inc., Ken Darling & Sons, Inc., WWES, Inc., and DNREC staff including DNREC Art Director Christy Shaffer, DNREC Public Affairs, and Environmental Scientist Jason Baumgartner. Funding was provided by a NonPoint Source 319 Grant.

Doc. # 40-08/01/07/03/02

©2019 Delaware Department of Natural Resources and Environmental Control (DNREC)







# Full Depth Gravity System

## Trench with aggregate

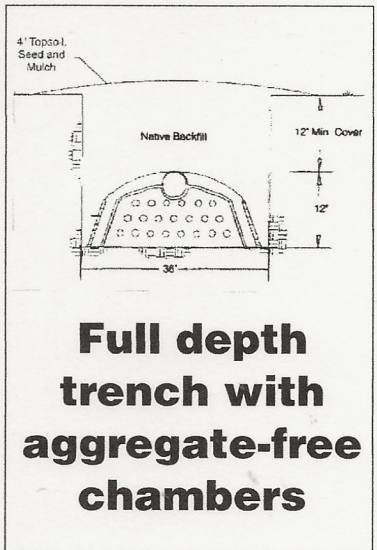
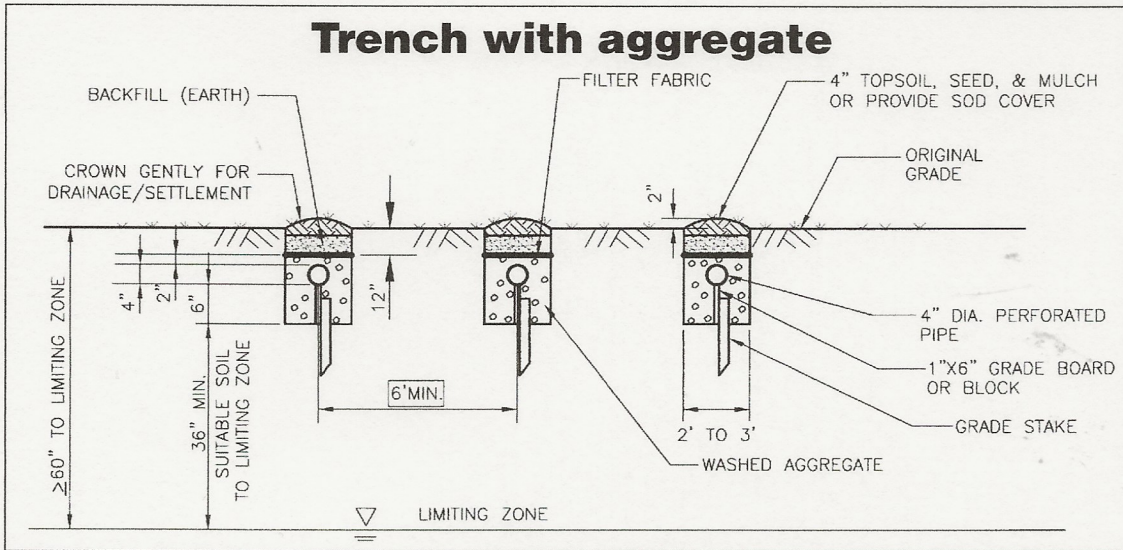

**Full depth trench with aggregate-free chambers**

## Bed with aggregate

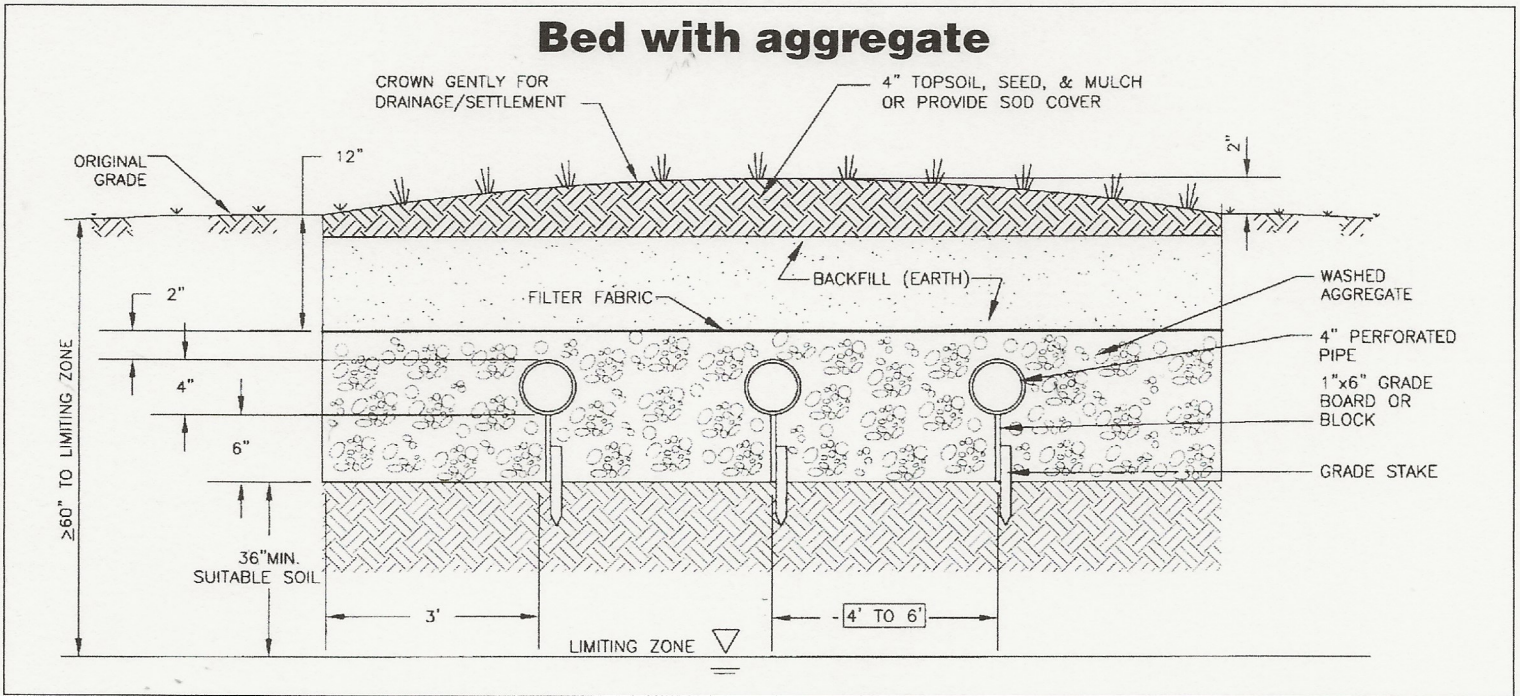

## Septic tank

PLAN

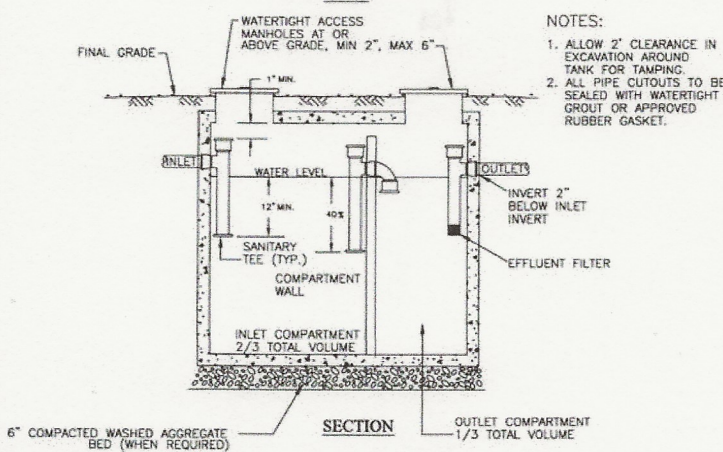

NOTES:

1. ALLOW 2" CLEARANCE IN EXCAVATION AROUND TANK FOR TAMPING.
2. ALL PIPE CUTOUTS TO BE SEALED WITH WATERTIGHT GROUT OR APPROVED RUBBER GASKET.

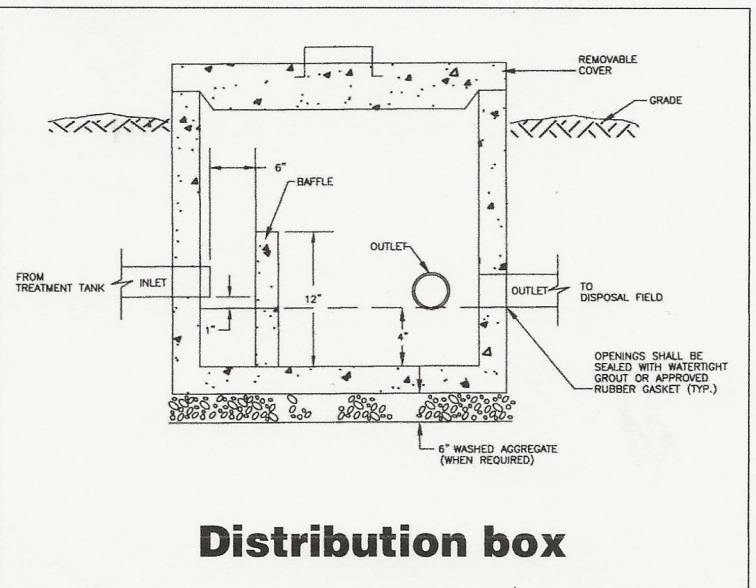

**Distribution box**



# Gravity Capping Fill System

## Trench with aggregate

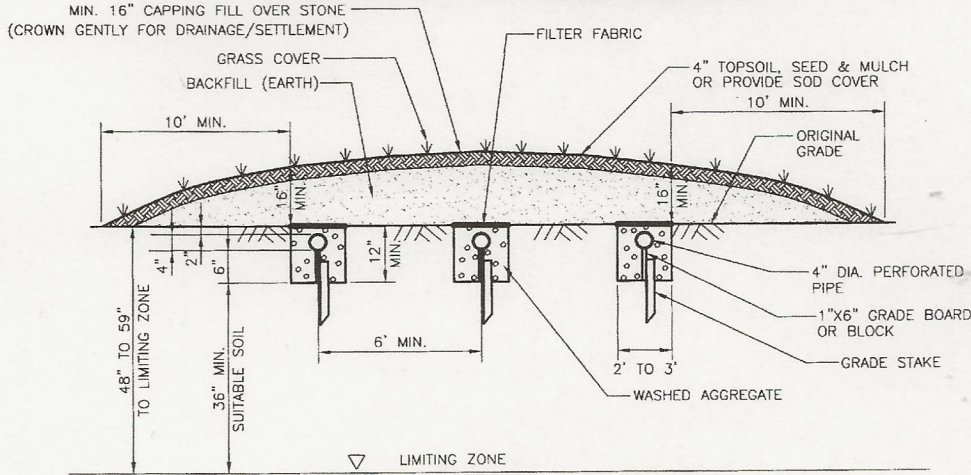

## Trench with aggregate-free chambers

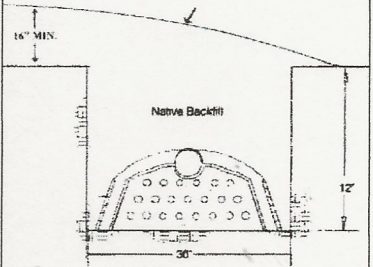

## Bed with aggregate

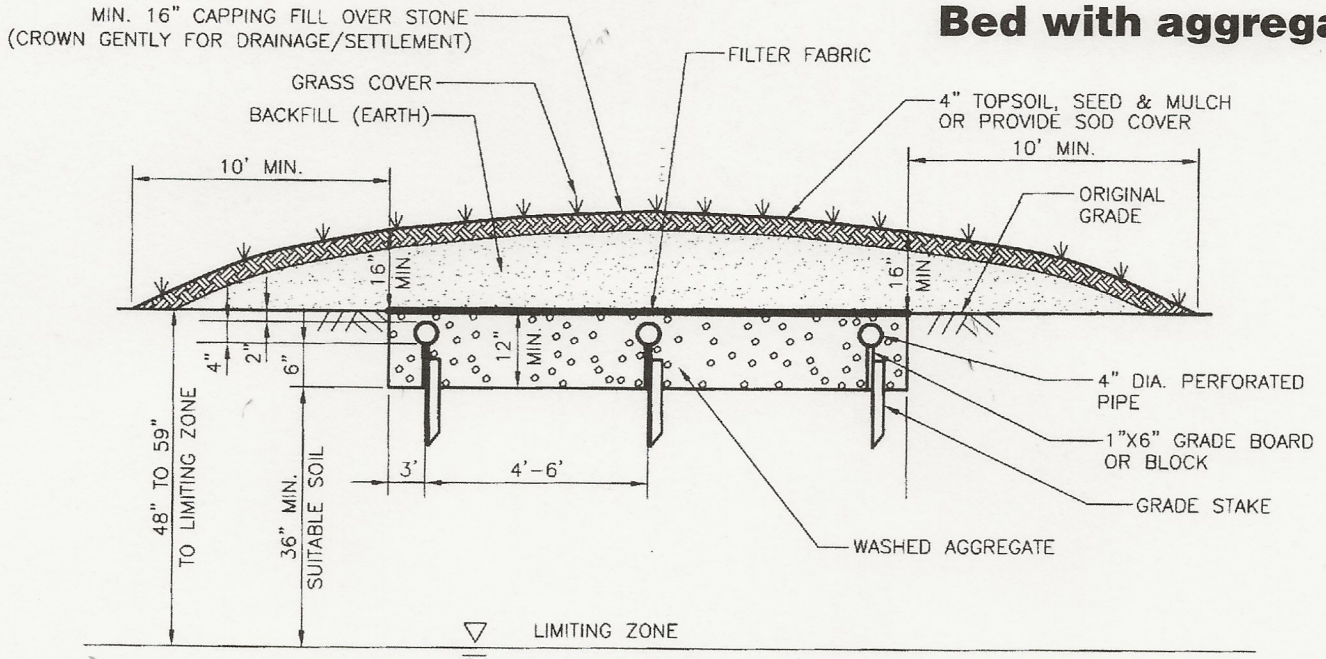

## Septic tank

PLAN

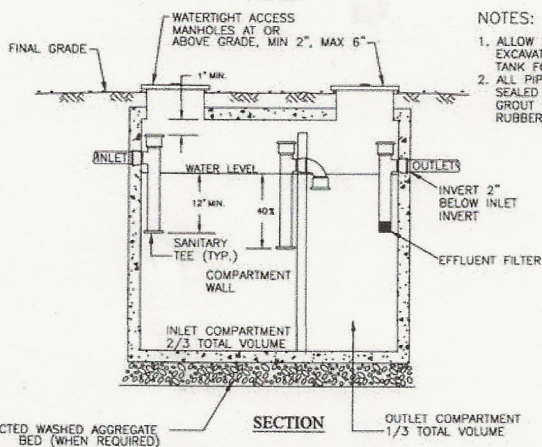

NOTES:

1. ALLOW 2' CLEARANCE IN EXCAVATION AROUND TANK FOR TAMPING.
2. ALL PIPE CUTOUTS TO BE SEALED WITH WATERTIGHT GROUT OR APPROVED RUBBER GASKET.

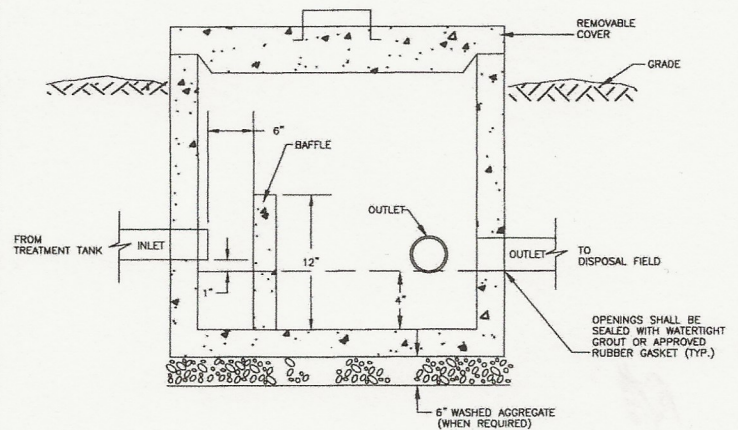

## Distribution box



# Low Pressure Pipe System

## Full depth installation

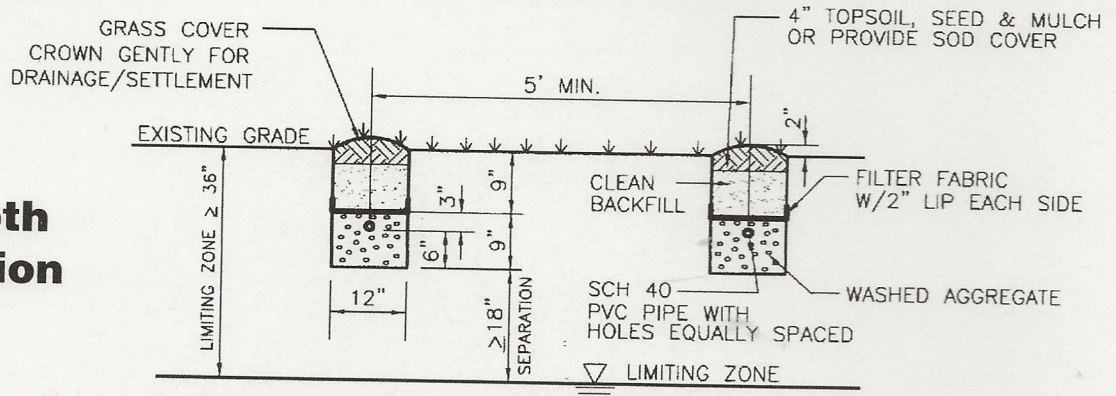

## Capping fill installation

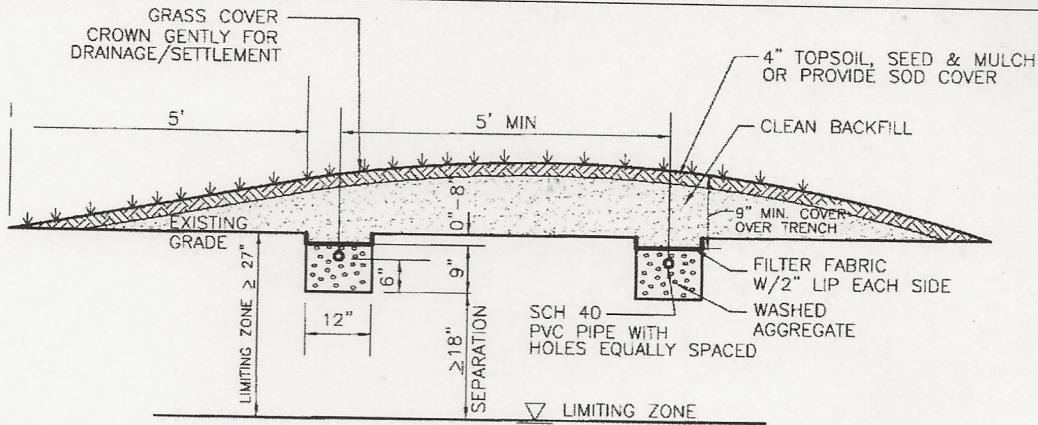

## Typical distribution system layout

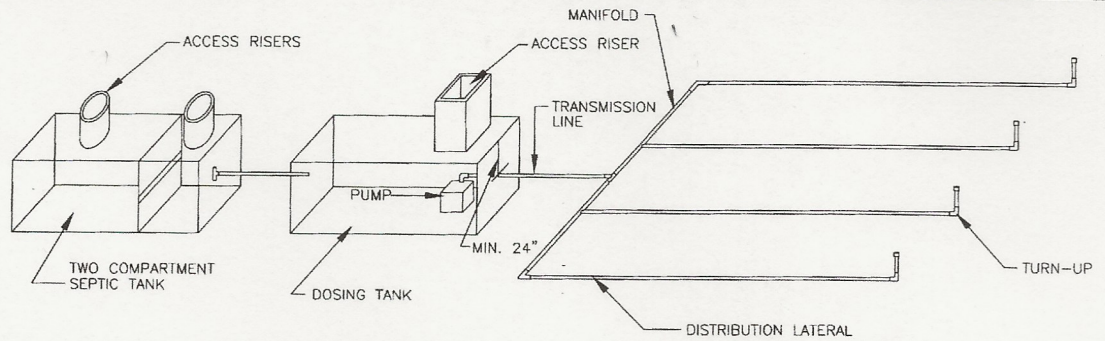

## Septic tank

PLAN

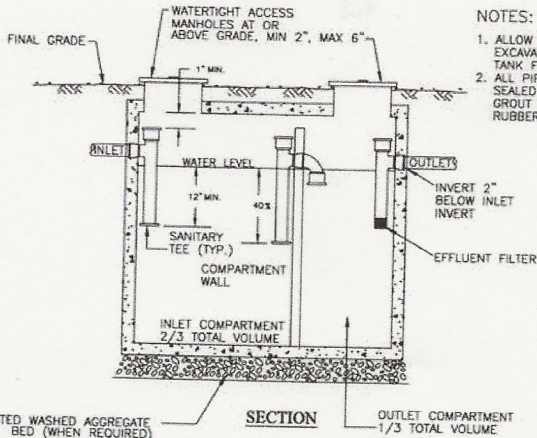

NOTES:

1. ALLOW 2" CLEARANCE IN EXCAVATION AROUND TANK FOR TAMPING.
2. ALL PIPE CUTOITS TO BE SEALED WITH WATERTIGHT GROUT OR APPROVED RUBBER GASKET.

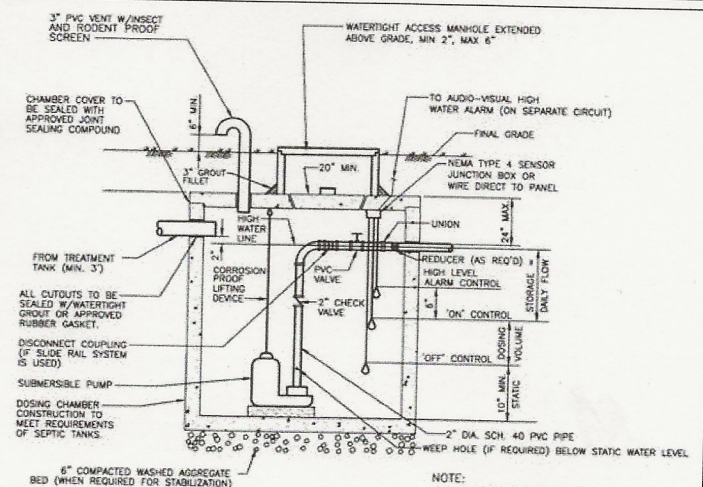

## Dosing tank







# Peat System

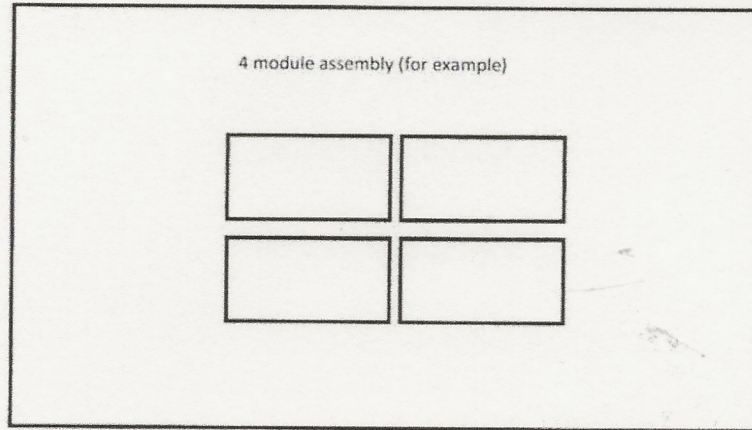

Plan View

Backfill compact to existing grade

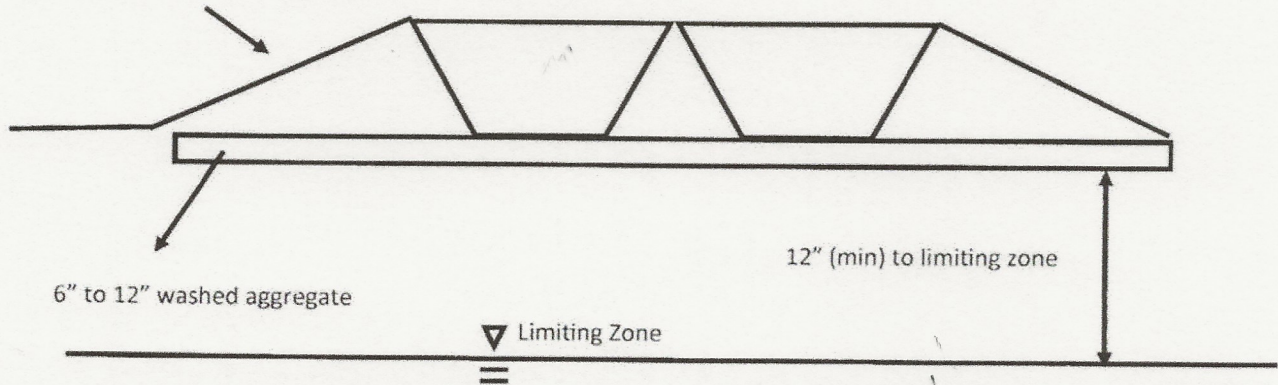

# Septic tank

PLAN

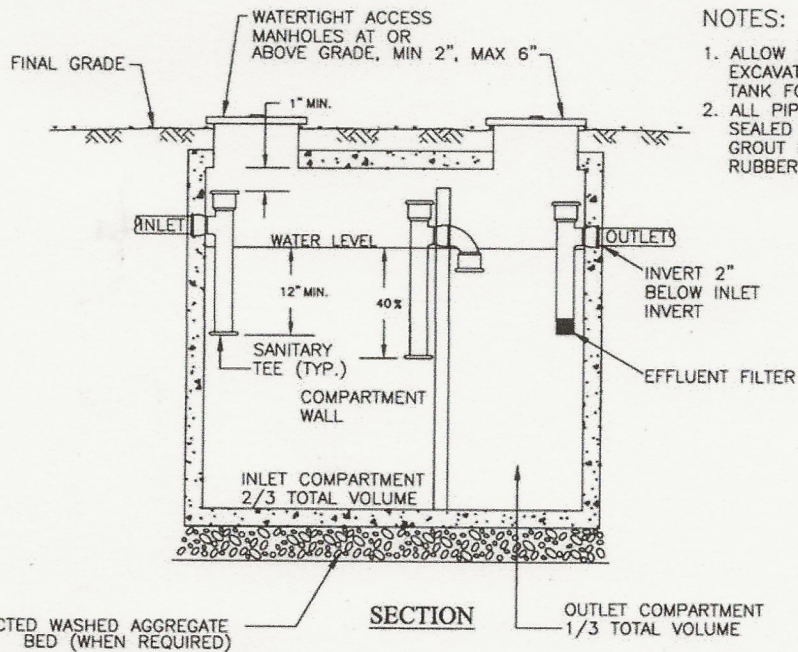

NOTES:

1. ALLOW 2' CLEARANCE IN EXCAVATION AROUND TANK FOR TAMPING.
2. ALL PIPE CUTOUTS TO BE SEALED WITH WATERTIGHT GROUT OR APPROVED RUBBER GASKET.